

# Wobbly Pulpit Repair

The illustration to the right shows a basic pulpit cabinet with an LDS2004A pulpit lift installed.

## Step 1:

Before proceeding with any repairs disconnect all power from the lift mechanism by unplugging the black control box in the upper left corner of the cabinet from its power source.

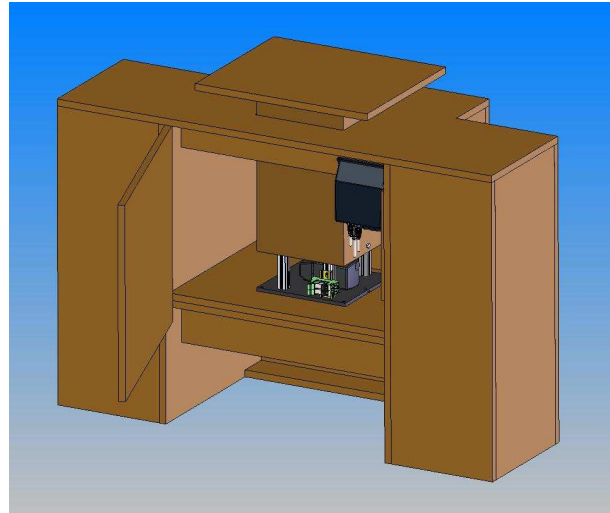

## Step 2:

Using a 7/16" hex wrench or socket remove the two 1/4-20UNC x 1-1/4" hex bolts that hold the lectern and neck assembly of the pulpit to the lift mechanism.

Disconnect the microphone cable from its source.

Lift the lectern and neck assembly up off of the lift mechanism and set it on the rostrum floor.

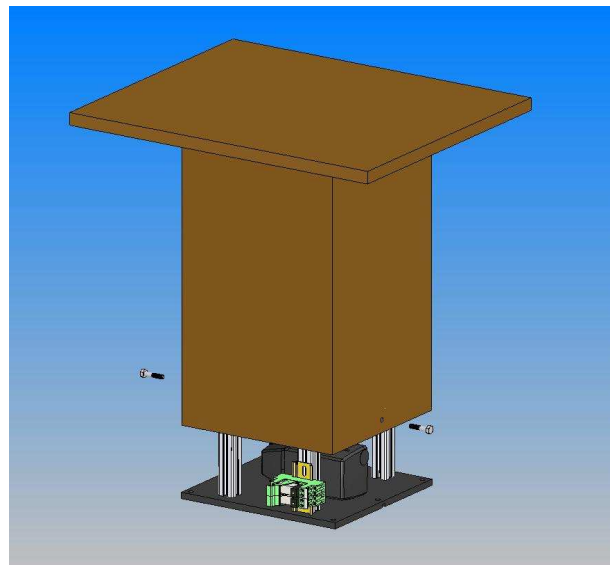

## Step 3:

Using a No. 28 Torx driver, remove the three screws that hold the blue (in some cases black) switch ring from the black steel switch plate as shown in this illustration.

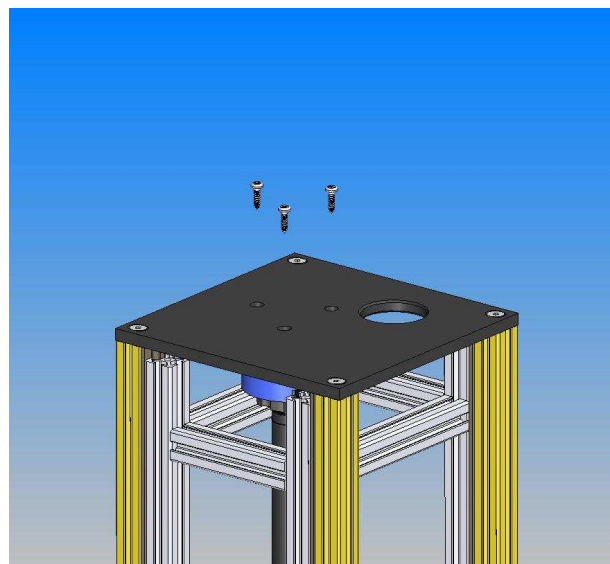

Step 4:

Lift the top half of the lift mechanism up and off of the base frame as shown here.

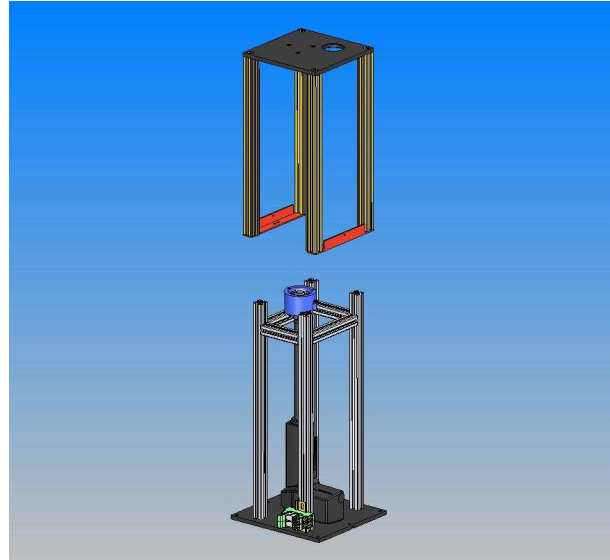

Step 5:

**IMPORTANT:** Be careful not to damage the microphone in this step!

Turn the lectern and neck assembly upside down and rest it on something steady.

Insert the top half of the lift mechanism (removed in Step 4) into the neck and lectern assembly as shown here.

The black steel plate of the lift mechanism must sit flat on the bottom of the lectern as show in this illustration.

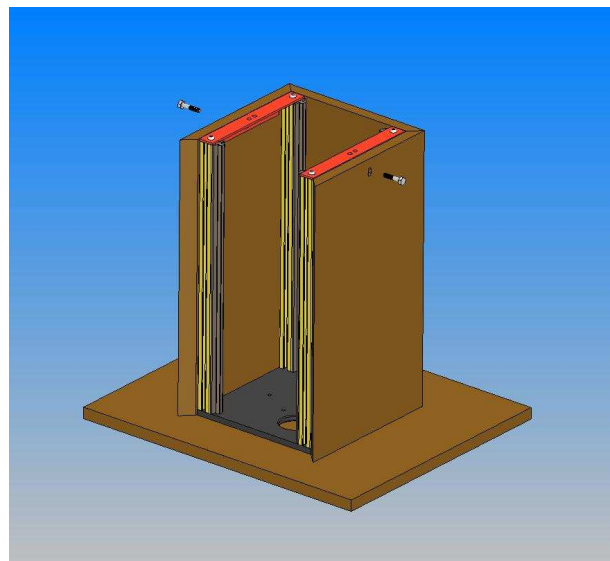

If the holes in the neck used to attach the neck to the lift mechanism with the hex bolts do not line up with the taped holes in the aluminum angles (shown here in red), use a drill motor and bit to slot them so that they do.

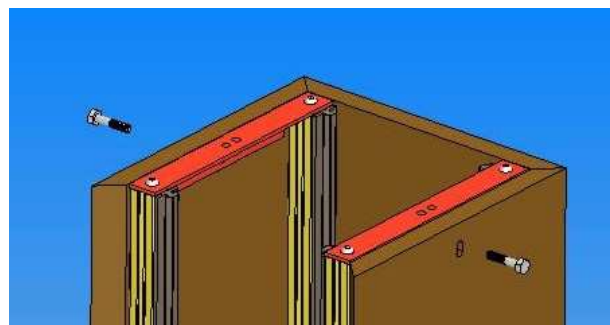

Step 6:

Using a 3/16" hex wrench (Allen wrench) loosen the four 1/4-20UNC button head screws shown here removed.

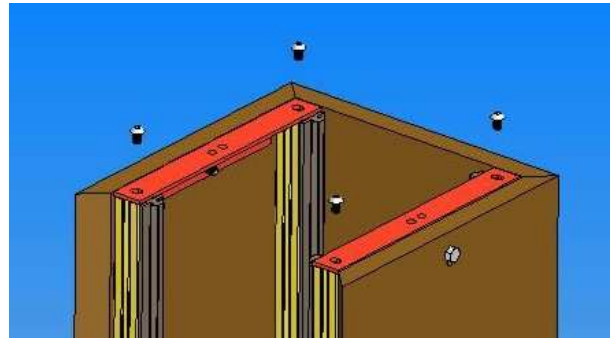

Step 7:

Remove the top half of the lift assembly from the neck and lectern and re-install it on to the base of the lift mechanism. For reference see Step 4 above.

Re-install the three Torx screws that hold the switch ring to the top plate of the lift mechanism. For reference see Step 3.

Re-install the neck and lectern assembly on to the lift mechanism. Do not tighten the 1/4-20UNC hex bolts completely. For reference see Step 2.

Reconnect power to the lift's control box. For reference see Step 1.

Run the lift up approximately half way (6 inches) using the Bishop's control panel.

Tighten the 1/4-20UNC hex bolts. Lower the lift. If the lift stops lowering at any point, loosen the hex bolts and continue to lower the lift. If you need to do this, you will need to place a shim, such as a washer, between the aluminum angles and the neck of the lectern. Repeat this process until you can operate the lift over its entire movement without a problem. After you are successful tighten the four 1/4-20UNC button head screws that you loosened in Step 6. Re-test the operation of the lift.

The lift is now installed properly.

This lift contains a safety feature that prevents the pulpit from pinching an object, such as a person's hand. It also contains a feature that limits the amount of load that the pulpit can lift. This prevents someone from riding on the pulpit. Both of these features are contained in the safety switch that connects the lift together. The safety switch contains a spring, so by its nature the lectern will never be completely ridged.

If you have any questions please contact me.

Mark Eaton  
Ph: 801-756-5639  
Fax: 801-406-7600